

DESIGN NOTES

Efficient DC/DC Converter Provides Two 15A Outputs from a 3.3V Backplane – Design Note 278

David Chen

Introduction

The 3.3V DC bus has become popular for broadband networking systems, where it is tapped for a variety of lower voltages to power DSPs, ASICs and FPGAs. These lower voltages range from 1V to 2.5V and often require high load currents. To maintain high conversion efficiency, power MOSFET conduction losses from the step-down converters must be minimized. The problem is that the 3.3V bus also brings with it frequent use of sub-logic level MOSFETs. Such MOSFETs have a relatively high $R_{DS(ON)}$, limiting the full-load efficiency of a converter to

around 85%. A more efficient solution is to use logic-level MOSFETs, which have very low $R_{DS(ON)}$ but require a 5V supply. The LTC[®]1876 allows the use of logic-level MOSFETs by combining a 1.2MHz boost regulator, which produces a 5V bias supply from a 3.3V input, with two step-down controllers, which provide the low voltage outputs. By integrating all three regulators in a single IC, the LTC1876 makes for efficient power supplies that can be small and inexpensive.

LTC and LT are registered trademarks of Linear Technology Corporation. Burst Mode is a registered trademark of Linear Technology Corporation.

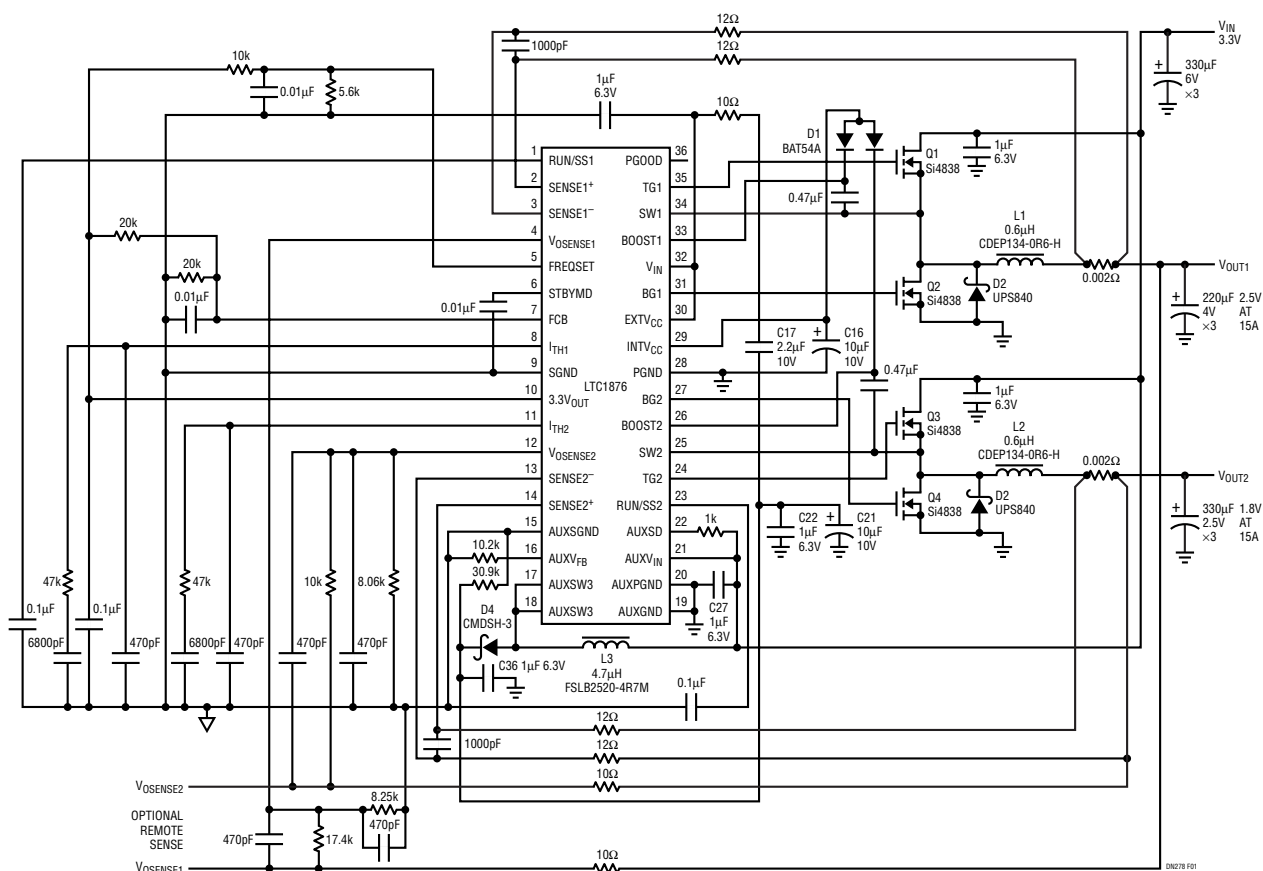

Figure 1. An LTC1876 Design Converts 3.3V to 2.5V at 15A and 1.8V at 15A

Design Example

Figure 1 shows a design that provides 2.5V/15A and 1.8V/15A from a 3.3V input. Because the LTC1876 provides a 5V bias for MOSFET gate drive, a very low $R_{DS(ON)}$ MOSFET Si4838 (2.4m Ω typical) can be used to achieve high efficiency. Figure 2 shows that the overall efficiency is above 90% over a wide range of loads.

Figure 2 also shows that the light load efficiency of this design is more than 84%. This is a direct benefit of the Burst Mode[®] operation of the LTC1876. Further efficiency improvements come from operating the two step-down channels out-of-phase. The top MOSFET of the first channel is fired 180° out of phase from that of the second channel, thus minimizing the RMS current through the input capacitors. This significantly reduces the power loss associated with the ESR of input capacitors. Figure 3 shows detailed current waveforms of this operation.

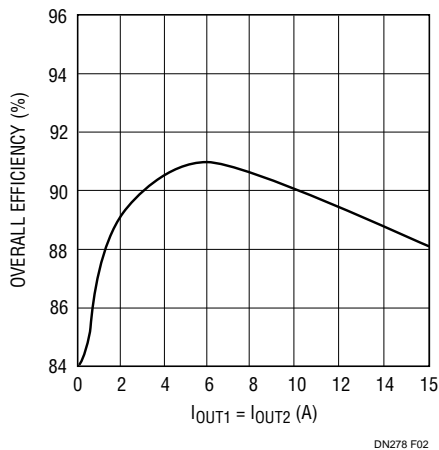

Figure 2. High Efficiency of the Design in Figure 1

Conclusion

The LTC1876 uses three techniques to efficiently power low voltage DSPs, ASICs and FPGAs from a low input voltage. The first technique uses an internal boost regulator to provide a separate 5V for the MOSFET gate drive. Secondly, its Burst Mode operation achieves high efficiency at light loads. Lastly is the out-of-phase technique which minimizes input RMS losses and reduces input noise. Complete regulator circuits are kept small and inexpensive, because all three switchers (one step-up regulator and two step-down controllers) are integrated into a single IC. For systems where a separate 5V is available or the input supply is greater than 5V, the internal boost regulator can be used to provide a third step-up output with up to 1A switch current.

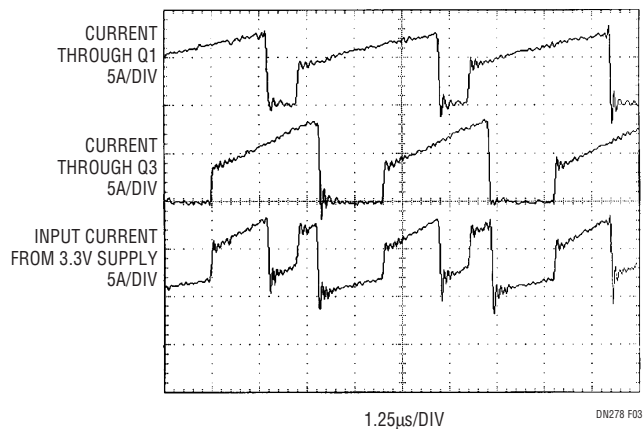

Figure 3. Each Switcher Has 5A Peak Current But the Total Ripple at the Input is Still only 5A, Minimizing C_{IN} Requirements

Data Sheet Download

<http://www.linear.com/go/dnLTC1876>

For literature on our Controllers,
call **1-800-4-LINEAR**. For applications help,
call (408) 432-1900, Ext. 2593